

Proposed Amendments on Corner Parcels

Figure 1: Buildable area applying proposed R-CG rules

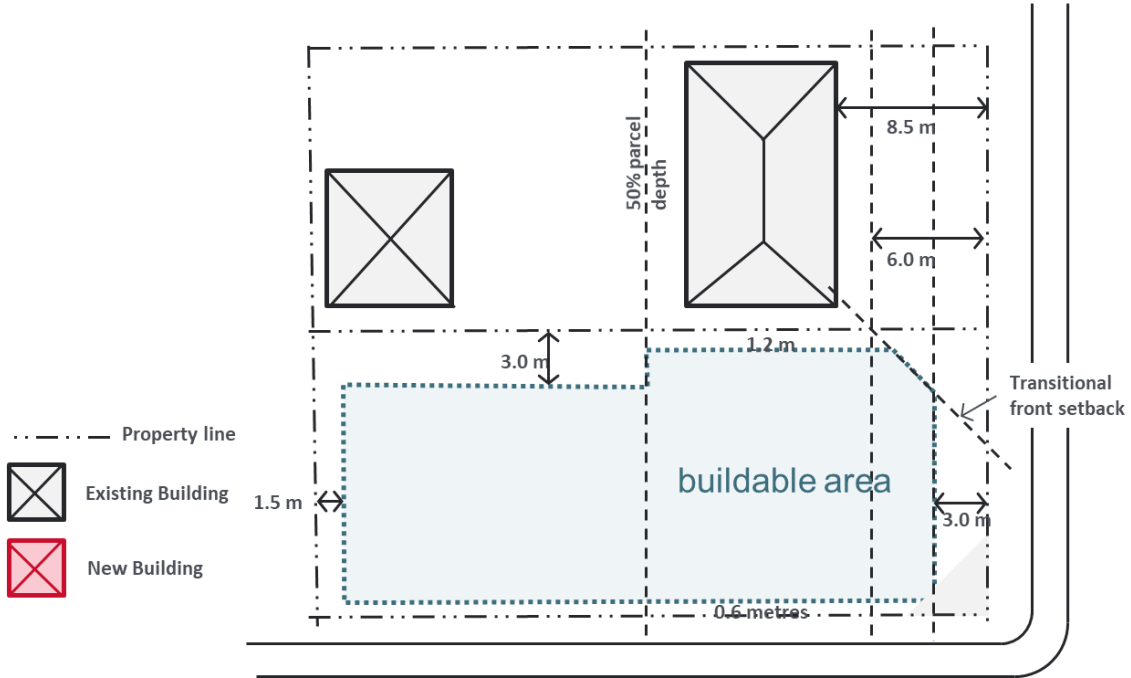
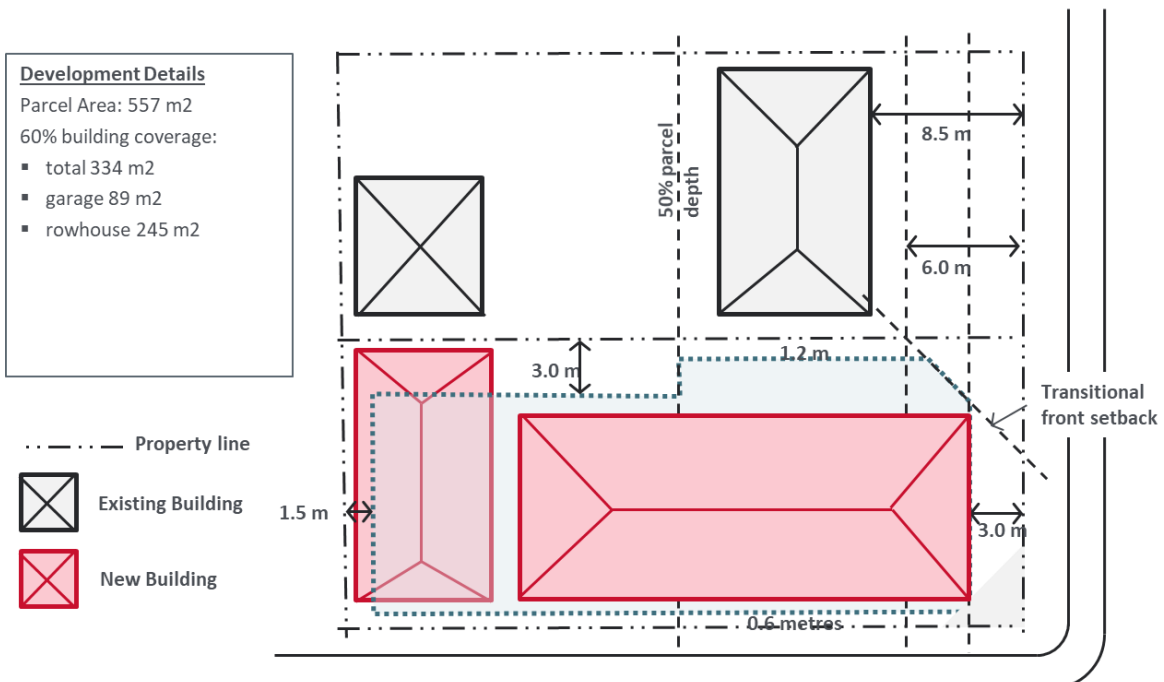

Figure 2: Rowhouse Building applying proposed R-CG rules



Proposed Amendments on Corner Parcels

Figure 3: Two Semi-detached Dwelling development applying proposed R-CG rules

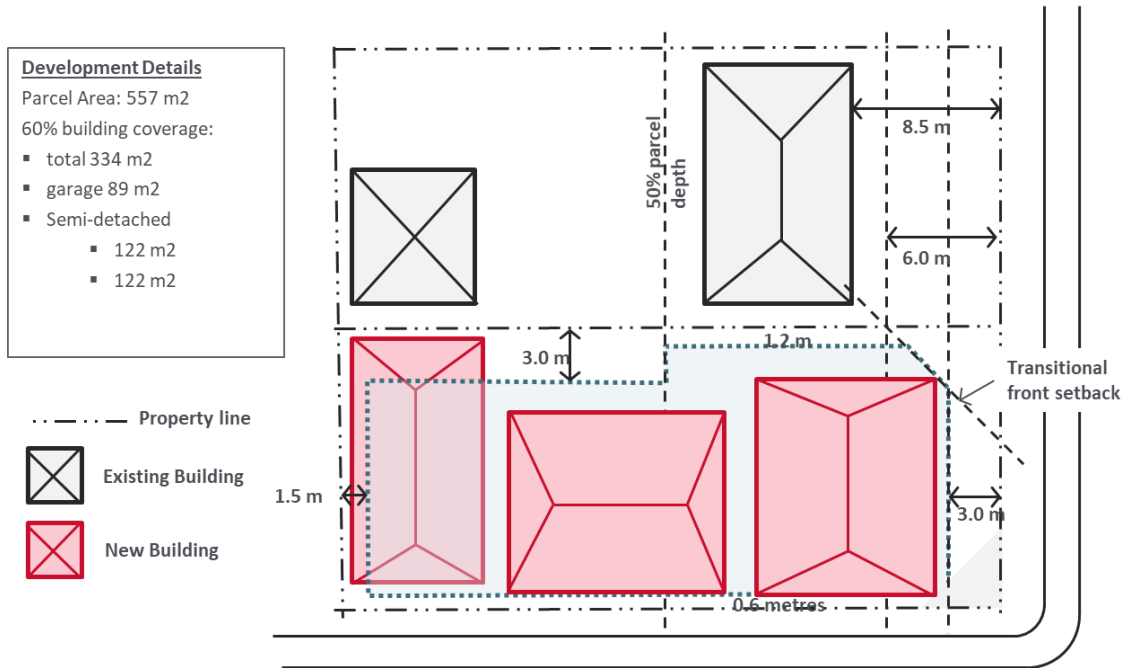
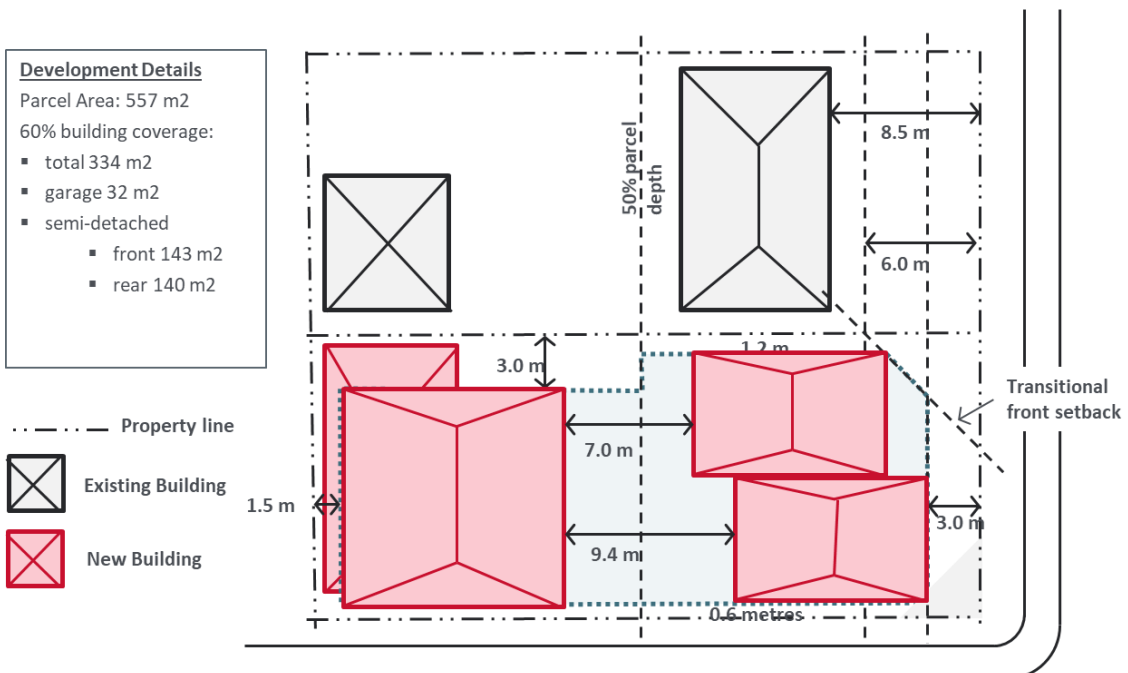

Figure 4: Courtyard style, two semi-detached development applying proposed R-CG rules



Proposed Amendments on Corner Parcels

Figure 5: Buildable area applying proposed R-CG rules adjacent to a new Semi-detached Dwelling

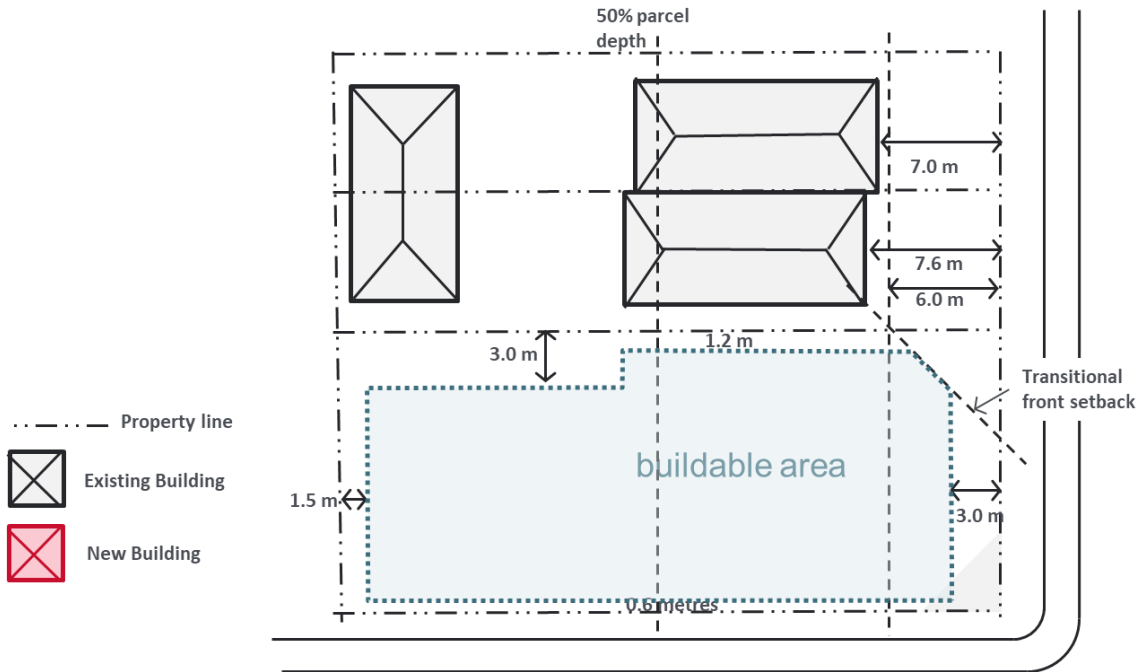

Figure 6: Two Semi-detached Dwelling development applying proposed R-CG rules adjacent to a new Semi-detached Dwelling

