



# Public Hearing of Council

## Agenda Item: 7.2.13



# LOC2023-0295 / CPC2024-1047

## Land Use Amendment

December 3, 2024

CITY OF CALGARY  
RECEIVED  
IN COUNCIL CHAMBER  
DEC 03 2024  
ITEM: 7-2-13 CPC2024-1047  
Distrib - Presentation  
CITY CLERK'S DEPARTMENT



## Calgary Planning Commission's Recommendation:

That Council:

Give three readings to **Proposed Bylaw 293D2024** for the redesignation of 0.08 hectare  $\pm$  (0.20 acre  $\pm$ ) located at 1116, 1120 and 1124 – 17 Avenue SW (Plan A1, Block 118, Lots 10 to 12) from Commercial – Corridor 1 f3.0h23 (C-COR1f3.0h23) District to Direct Control (DC) District.

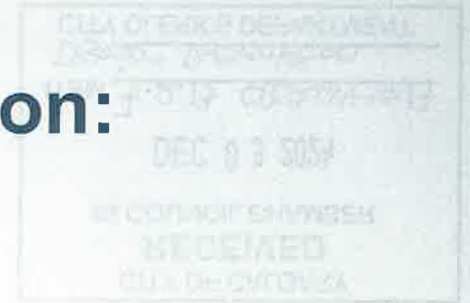



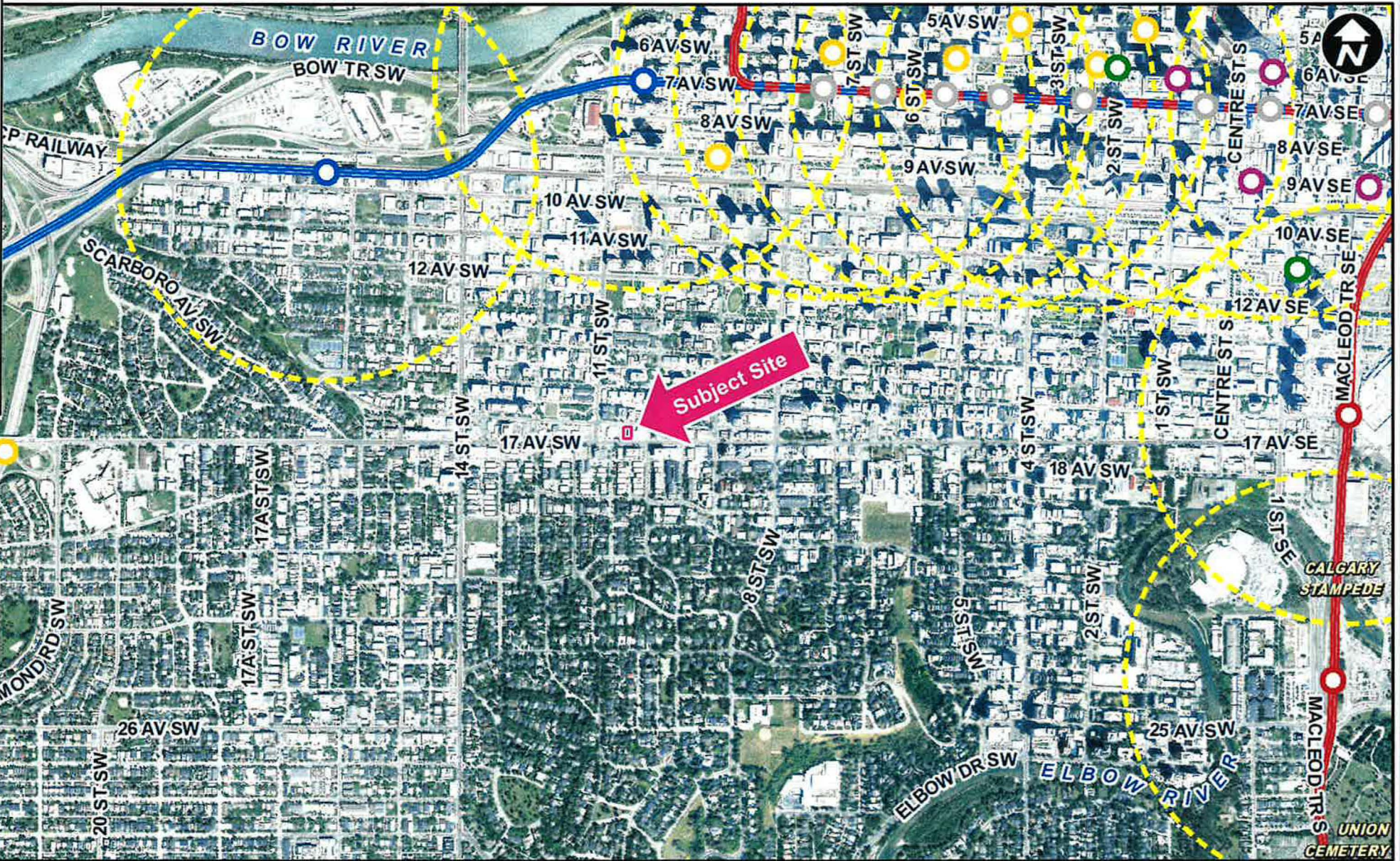
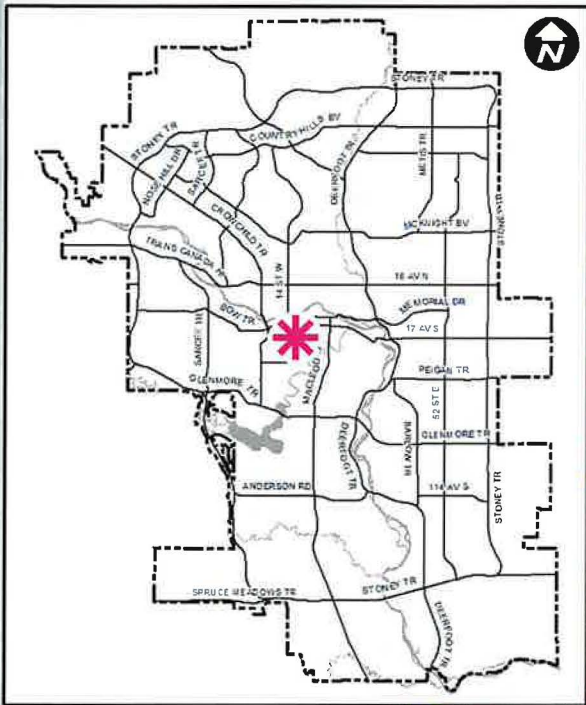

**LEGEND**

- 600m buffer from LRT station
- LRT Stations**
- Blue
- Downtown
- Red
- Green (Future)
- LRT Line**
- Blue
- Blue/Red
- Red
- Max BRT Stops**
- Orange
- Purple
- Teal
- Yellow



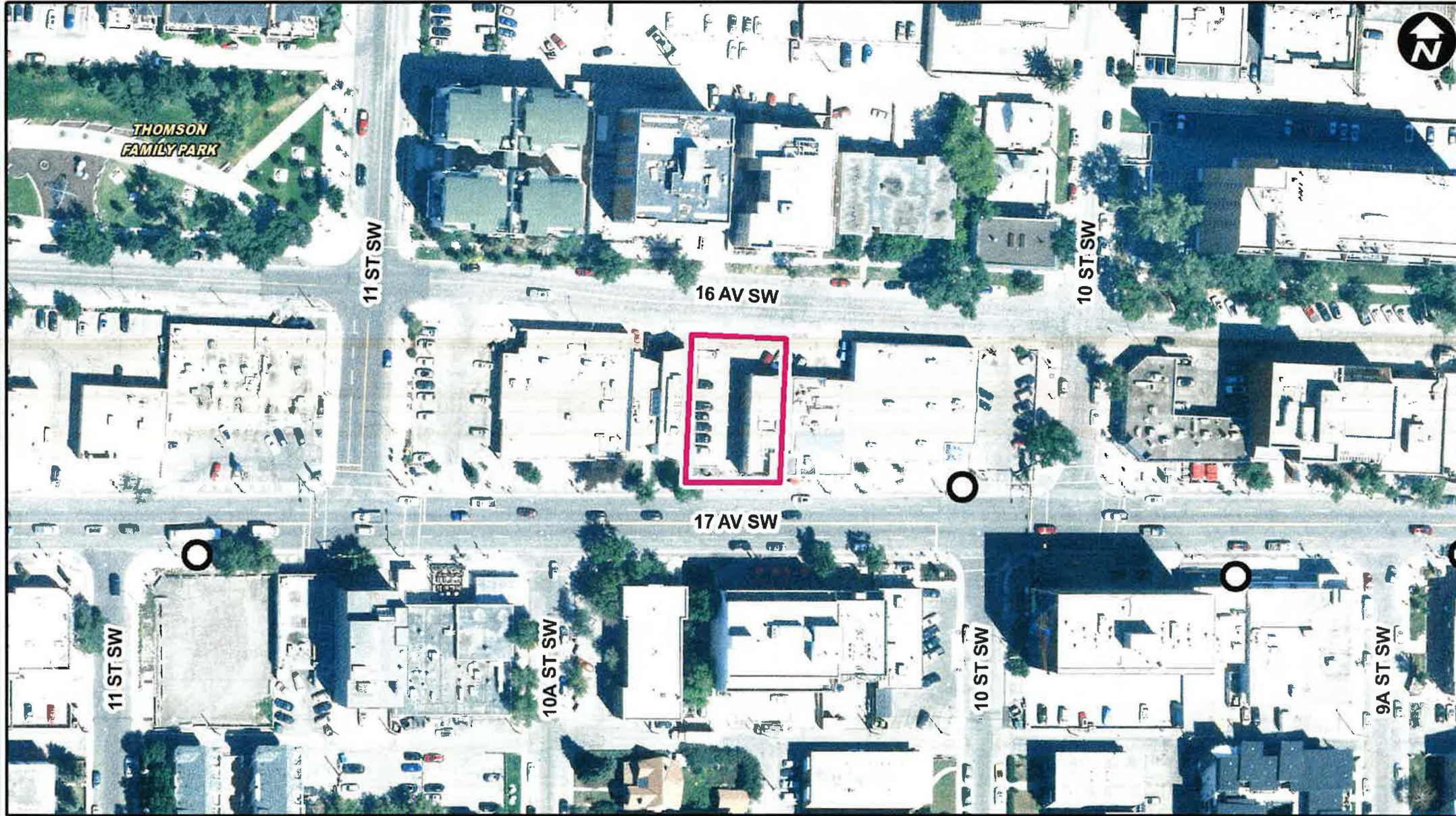

LEGEND

○ Bus Stop

Parcel Size:

0.08 ha

23m x 35m



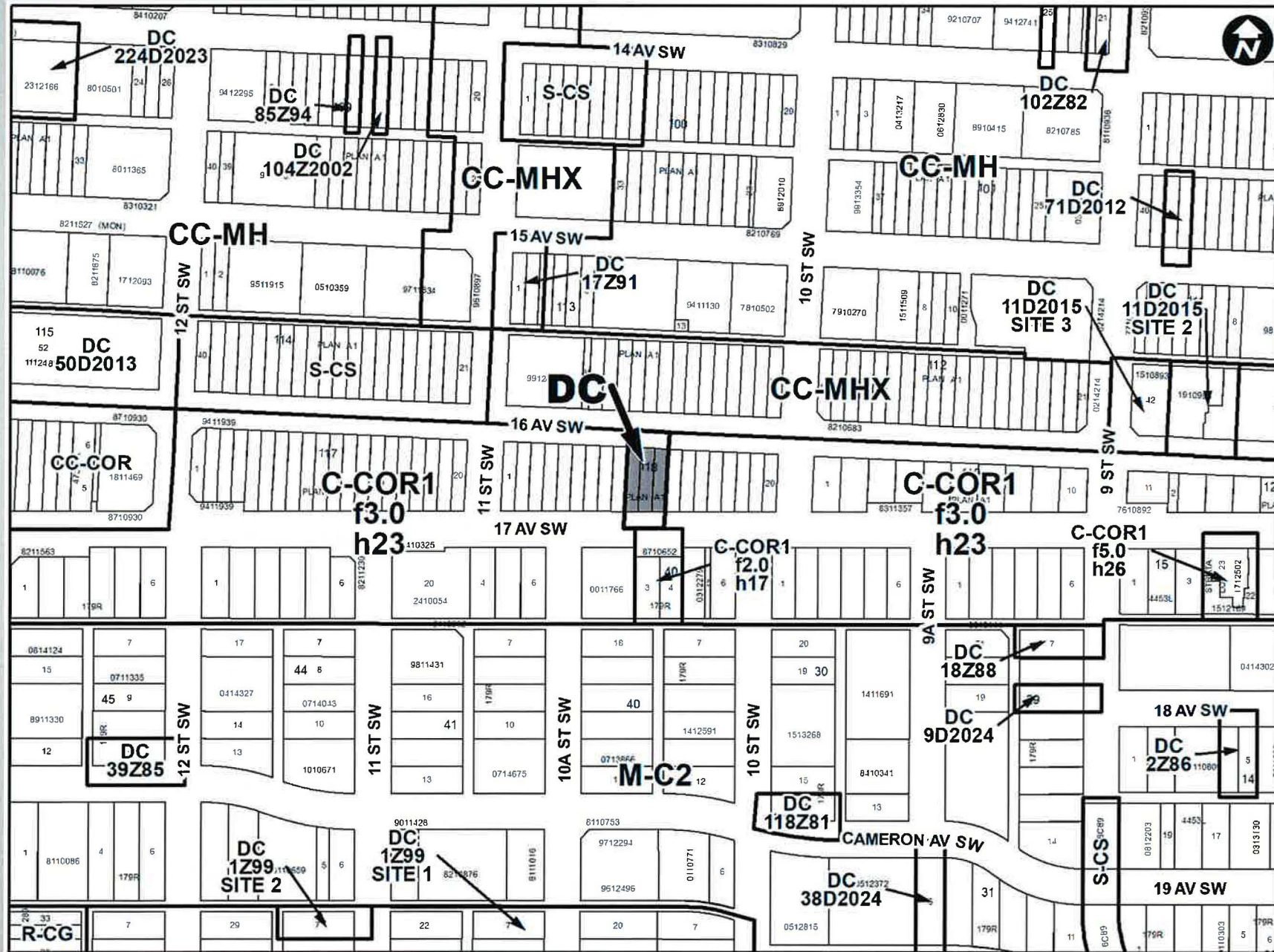

## Proposed DC District:

- Based on C-COR1 District
- Allow a Digital Sign with Electric Vehicle Charging Facility



## Calgary Planning Commission's Recommendation:

That Council:

Give three readings to **Proposed Bylaw 293D2024** for the redesignation of 0.08 hectare  $\pm$  (0.20 acre  $\pm$ ) located at 1116, 1120 and 1124 – 17 Avenue SW (Plan A1, Block 118, Lots 10 to 12) from Commercial – Corridor 1 f3.0h23 (C-COR1f3.0h23) District to Direct Control (DC) District.



# Supplementary Slides





DIMENSIONAL DRAWINGS

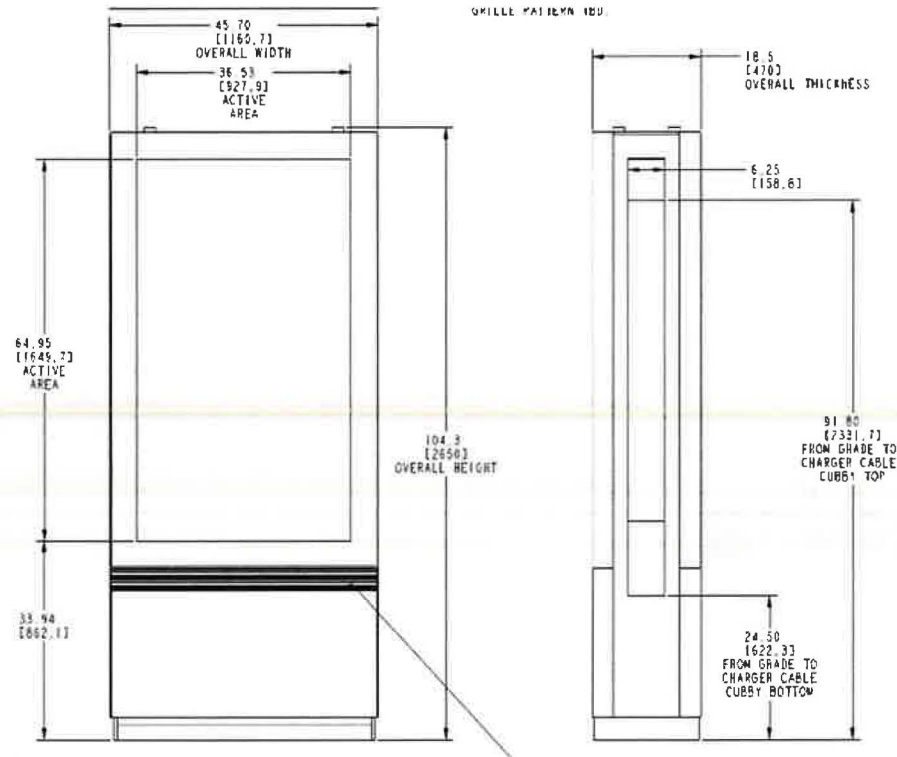

12

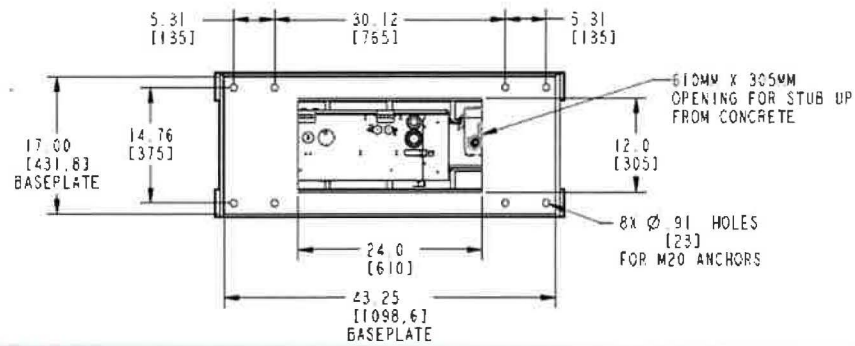

Proposed Electric Vehicle (EV) Charger:

- Dimensions: 2.65 x 1.16 x 0.47 metres











# Beltline Area Redevelopment Plan

## Map 3: Land Use Concept

- Located in an Urban Mixed-Use District.
- Supports vibrant, pedestrian streets that are visually interesting and sensitive to nearby residential uses.

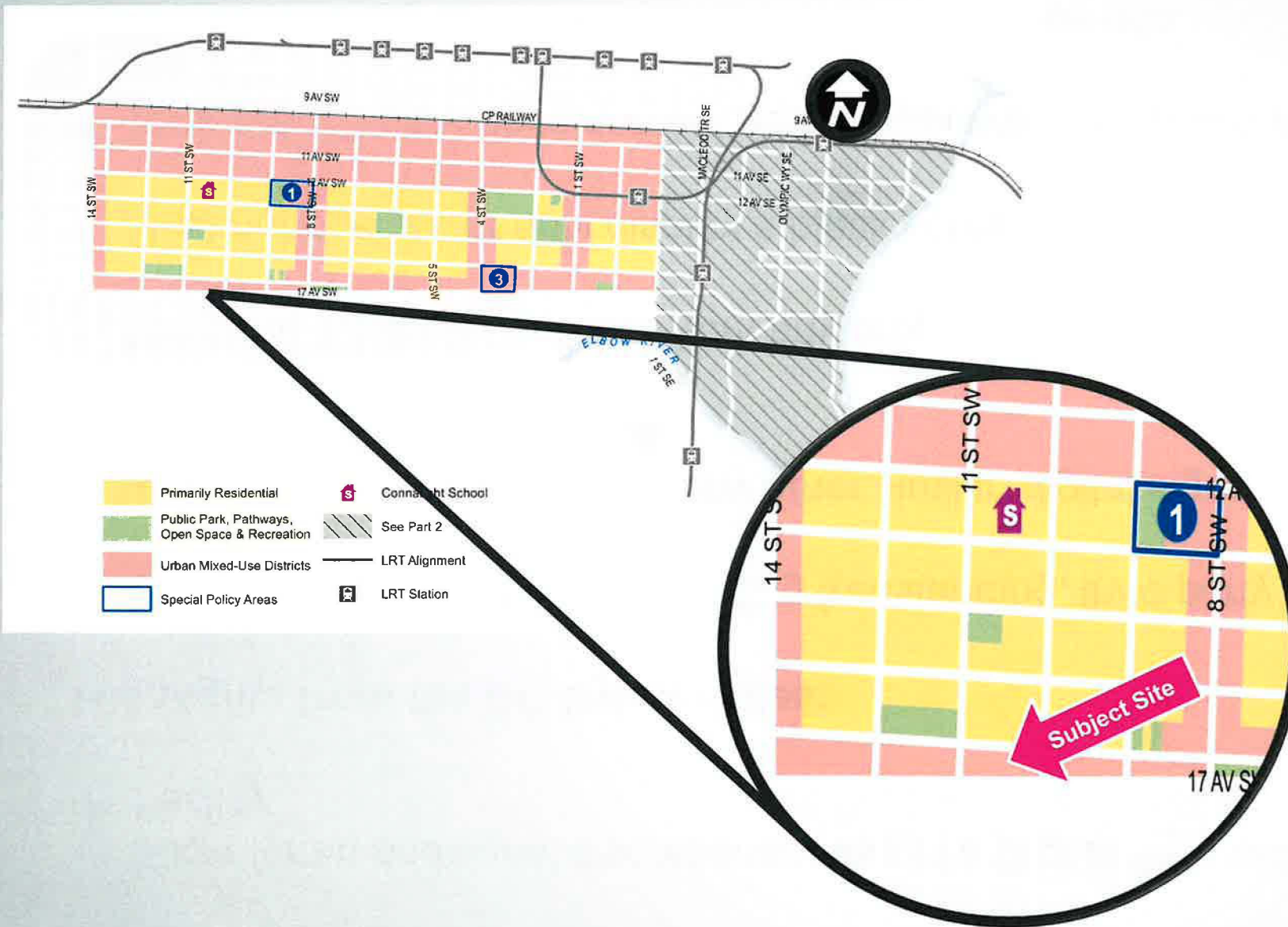



## Purpose:

- Allow for an additional discretionary use of a Digital Sign with Electric Vehicle Charging Facility.

## Highlights from the DC Bylaw Rules:

- 15.0 metre separation from existing freestanding, third party and other digital signs on site.
- 300.0 metre separation from any other similar, digital signs and 75.0 metres from any other third-party advertising signs.
- Minimum 1.5 metre setback from any property line shared with a street.
- Must not operate or only display a black screen between 11 p.m. and 6 a.m.
- Temporary 3-year development permit approval with option to renew.
- Would allow advertisement of businesses on or off-site.



## Defined Uses

### 4 In this Direct Control District:

(a) “**Digital Sign with Electric Vehicle Charging Facility**” means a structure:

(i) that includes a **Sign – Class G** that:

(A) displays **copy** directing attention to a business, commodity, service or entertainment that is conducted, sold or offered on or off-site;

(B) must not exceed a height of 2.7 metres from **grade** when measured adjacent to the structure;

(C) includes a maximum of one **sign** on the parcel, which may be double-faced;

(D) has **copy area** facing each direction that must not exceed 1.6 square metres; and





(i) where electric vehicles are supplied with electricity for the purpose of charging.



## Intent

- Promote community aesthetics and public safety.
- Prevent visual clutter from sign proliferation.
- Protect Calgary’s communities and visual environment.

## Supporting Principles

<p><b>(A) I. The appropriate location is generally commercial, along Arterial Streets and Urban Boulevards.</b>  <i>Review: The site is commercial and fronts a Neighbourhood Main Street (17 Ave. SW), which is similar to an Urban Blvd.</i></p>	
<p><b>(A) IV. Must be pedestrian-oriented, protect quality residential environment and consider competition with on-site businesses.</b>  <i>Review: The proposed sign structure is pedestrian-scaled, development permit conditions will manage visual impacts. The sign could include advertising of on-site businesses, and its size limits its competition with existing on-site signage.</i></p>	
<p><b>(A) V. Maintain the visual amenity of roads adjacent to or passing through residential communities.</b>  <i>Review: The orientation of the sign reduces visibility from nearby residential and the location will be reviewed through the development permit application process.</i></p>	
<p><b>(B) I. The orientation, distance and location should minimize visual intrusion to residences, parks and natural areas</b>  <i>Review: The orientation of the sign may reduce visibility from residences and the site location will be reviewed through the development permit application process.</i></p>	
<p><b>(C) VI. Pedestal type signs are suitable where commercial development is on both sides of the street</b>  <i>Review: The scale and orientation of the sign fits well within the context and character of the area.</i></p>	



# Surrounding Land Use 15

- LEGEND**
- Single detached dwelling
  - Semi-detached / duplex detached dwelling
  - Rowhouse / multi-residential
  - Commercial
  - Heavy Industrial
  - Light Industrial
  - Parks and Openspace
  - Public Service
  - Service Station
  - Vacant
  - Transportation, Communication, and Utility
  - Rivers, Lakes
  - Land Use Site Boundary

