

Calgary



URBAN DESIGN REVIEW PANEL

2023 June 14

C2023-0531
Attachment 21b

Outline

- UDRP Overview
- Panel Workload
- 2023 Main Priorities

**Imagery shown in this document is available in the Public Realm and assumed to be copyright of the Applicant. Images on the following pages are accurate to the reviewed date and subject to change pending the approval process. Images are for visual interest only and not intended to form part of the discussion.*



UDRP Overview

The Panel's mandate is to **provide independent and professional urban design and architectural advice.**

The Panel provides comments on development proposals that may have a significant impact on the public realm.

The Panel reviews and comments on:

- pre-application enquiries,
- land use redesignation,
- development permit applications,
- development liaisons on sites citywide.

Comments are **provided as peer review** recommendations to encourage best practices by **identifying areas for improvement to support better design outcomes..**

The Panel comments are distributed to City Staff, Calgary Planning Commission, and Council to inform the approval process.



Panel Selection Process

Skills matrix and diversity

- assists in the selection process for new panel members
- includes professional affiliations and specialized skills
- supports focus on getting to the best balance of skill sets while working to ensure gender balance and diversity overtime
- ensures a balance of skills and experience is maintained through staggered terms.

Panel members attended an Equity, Diversity and Inclusion session hosted by the City.

Member selection process

A more open and public selection process is attracting a broader range of applicants. This will continue to improve the potential to assemble a more diverse and inclusive panel in the future.



New and outgoing members

The panel welcomed one new member, Raphael Neurohr in 2022.

Thank you to the departing member and former chair Chad Russill for his contributions

Application Geography

UDRP reviews applications from across the city. From urban infill projects to new communities.

The projects range in complexity and context from affordable autocourt and auto-oriented midrise developments in the suburbs to important landmark buildings such as the BMO centre.

The panel considers the economics and context in their comments to provide design recommendations that are feasible for the type of project.

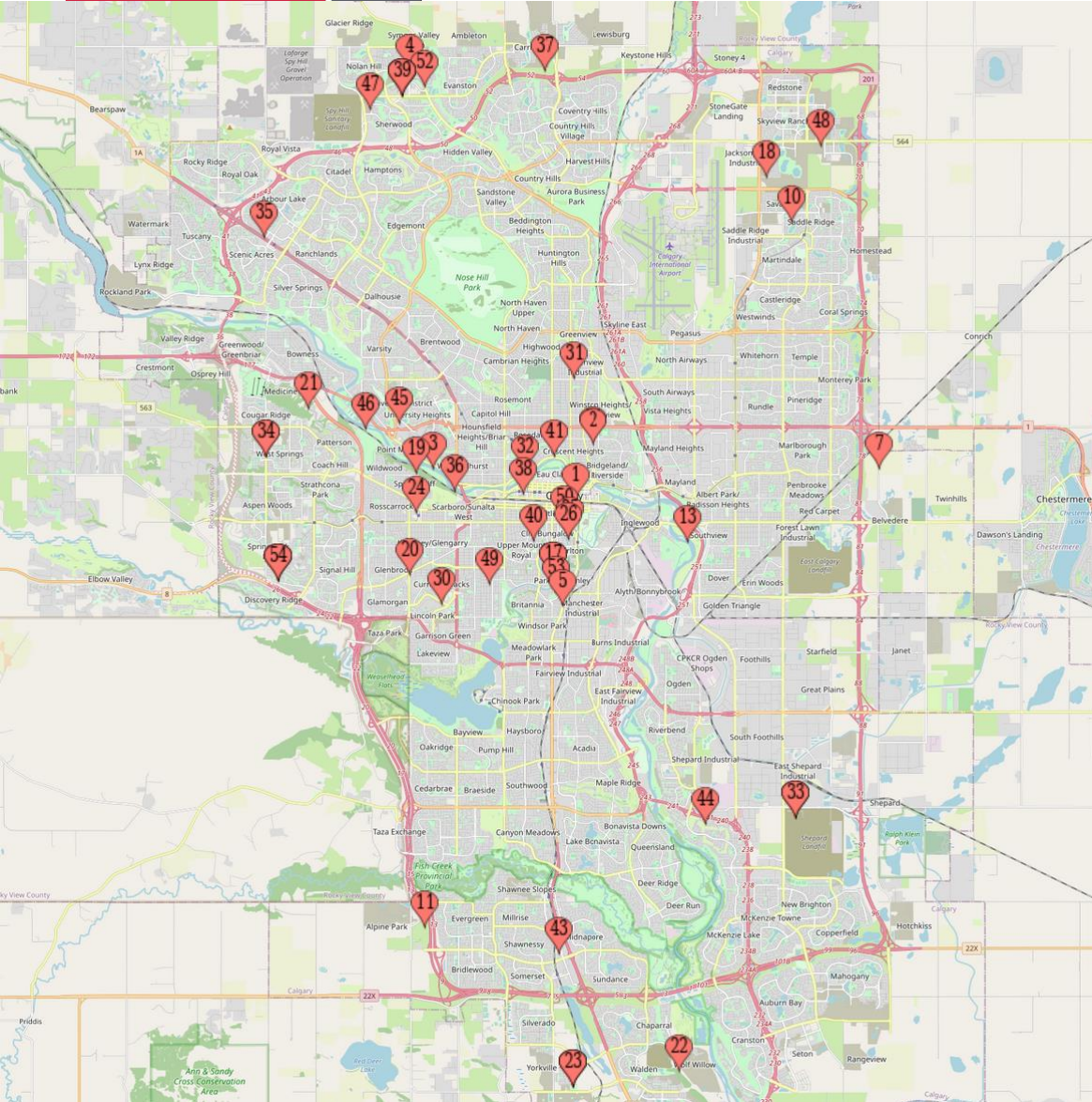

Panel Workload

The Panel meets every 2 weeks

1-3 projects are reviewed at each session.

There are 2 alternating UDRP teams

In addition, special sessions are also scheduled when required to accommodate higher application volumes

Panel members frequently swap sessions to accommodate individual commitments, conflicts of interest, etc.

The panel continues to review Pre-Application Enquiries and Land Use Amendments.

The early review of projects is the most effective opportunity to meaningfully impact design quality.



Panel Workload

File Review Volume

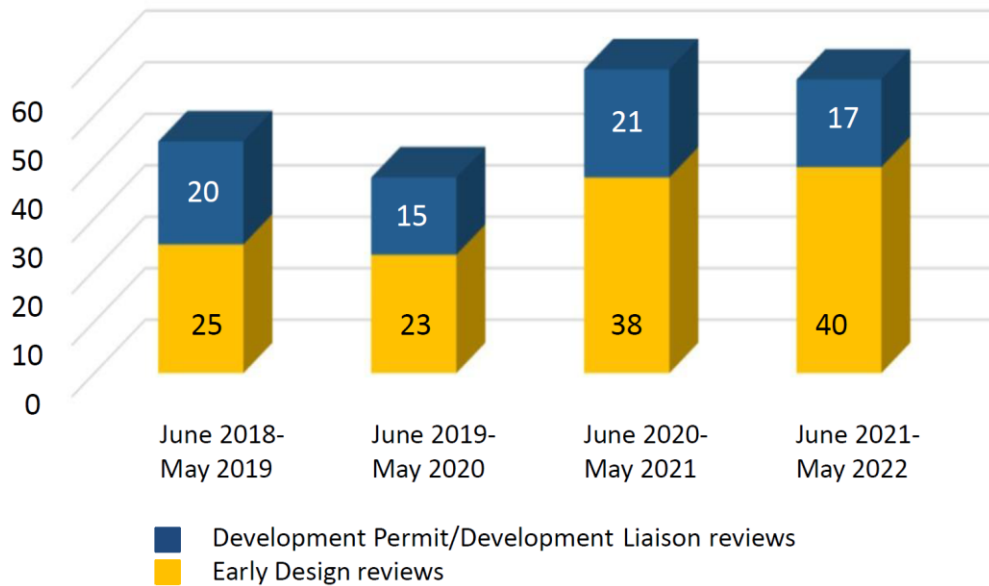

2022-2023

UDRP meetings	27
Regular scheduled sessions	24
Special sessions	3
Development Permit/Development Liaison reviews	34
Pre-application, schematic reviews	14
Land Use Amendment reviews	2
# total early design reviews	16
total applications reviewed	50

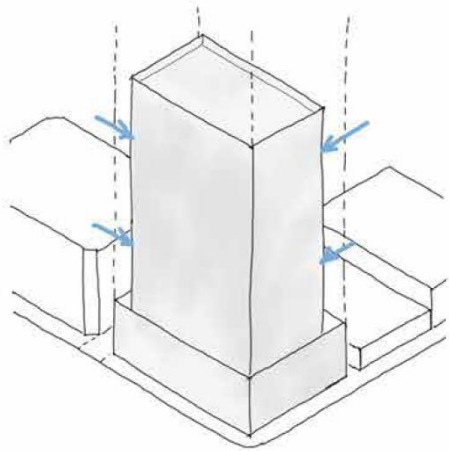

② Inset tower to generate a strong podium and provide scalar relief on the site corners

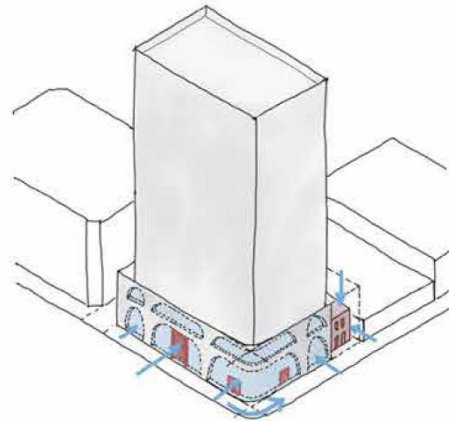

③ Engage the public realm with transparent street frontages, softened corners, and entrances. Acknowledge the existing heritage building through reduction of scale and additional setbacks.

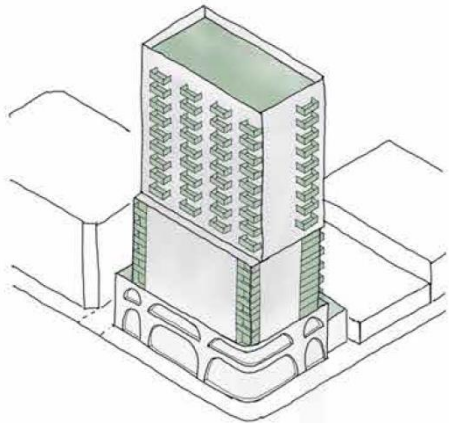

⑤ Integrate private and public amenity into void spaces and rooftops

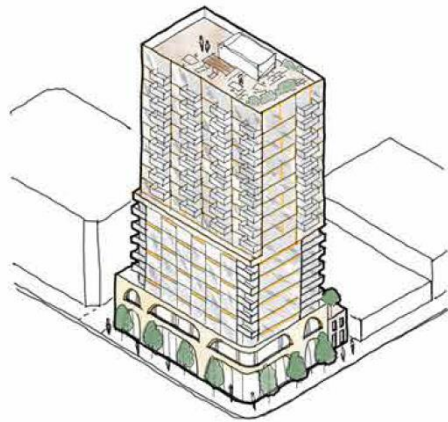

⑥ Utilize high quality materiality to become a landmark building on a prominent intersection

Time Commitment

Panel members

~120 hrs

Chairs

~150 hrs

Total

~1500 hrs

Equivalent to
(in professional fees)

~\$300,000

2023 Main Priorities

Priorities for the Panel for the upcoming year are:

- Collaborate with City Staff to ensure that the quality and consistency of submission package materials continues to improve.
- Develop comment guidelines to ensure that Panel comments are clear, consistent, and proactive to ensure an effective peer review relationship with applicants.
- Request that City Staff deliver Planning and Urban Design staff comments together with applicant packages for review in advance of meetings.



UDRP Impact

Urban Design Review Panel ensures that design quality is prioritized in the approvals process.

The impact of the UDRP is significant and wide-ranging.

Design quality helps to:

- maintain neighbourhood character.
- promote walkability.
- activate public streets.
- improve main street retail.
- attract tourism.
- foster city pride.
- build social cohesion.



Questions?